



BRADNAM'S

# HARDWARE RANGE



ESSENTIAL

SIGNATURE

COMMERCIAL



BRADNAM'S

## HARDWARE RANGE

The importance of hardware can be overlooked when considering all aspects of windows and doors. At Bradnam's we understand that hardware can have a dramatic effect on the overall design and functionality of windows and doors.

As such, our windows and doors are complemented by an extensive range of stylish and innovative hardware options. Whether you are a renovator, homeowner, builder or designer, our hardware range provides flexibility to help with your design concept.

## CONTENTS

WINDOW HARDWARE RANGE	3
DOOR HARDWARE RANGE	11
HARDWARE CARE & MAINTENANCE	20

**Note:** Key-locking versions are shown in this catalogue. Non key-locking versions are also available in some products.



BRADNAM'S

# WINDOW HARDWARE RANGE

SLIDING WINDOWS

DOUBLE HUNG WINDOWS

AWNING WINDOWS

BI-FOLD WINDOWS

CASEMENT WINDOWS

LOUVRE WINDOWS

Trim Concept Homes

# SLIDING WINDOWS

ESSENTIAL



SIGNATURE

Lever locks the window without a key



Mortice lock for improved security



# DOUBLE HUNG WINDOWS

ESSENTIAL

SIGNATURE

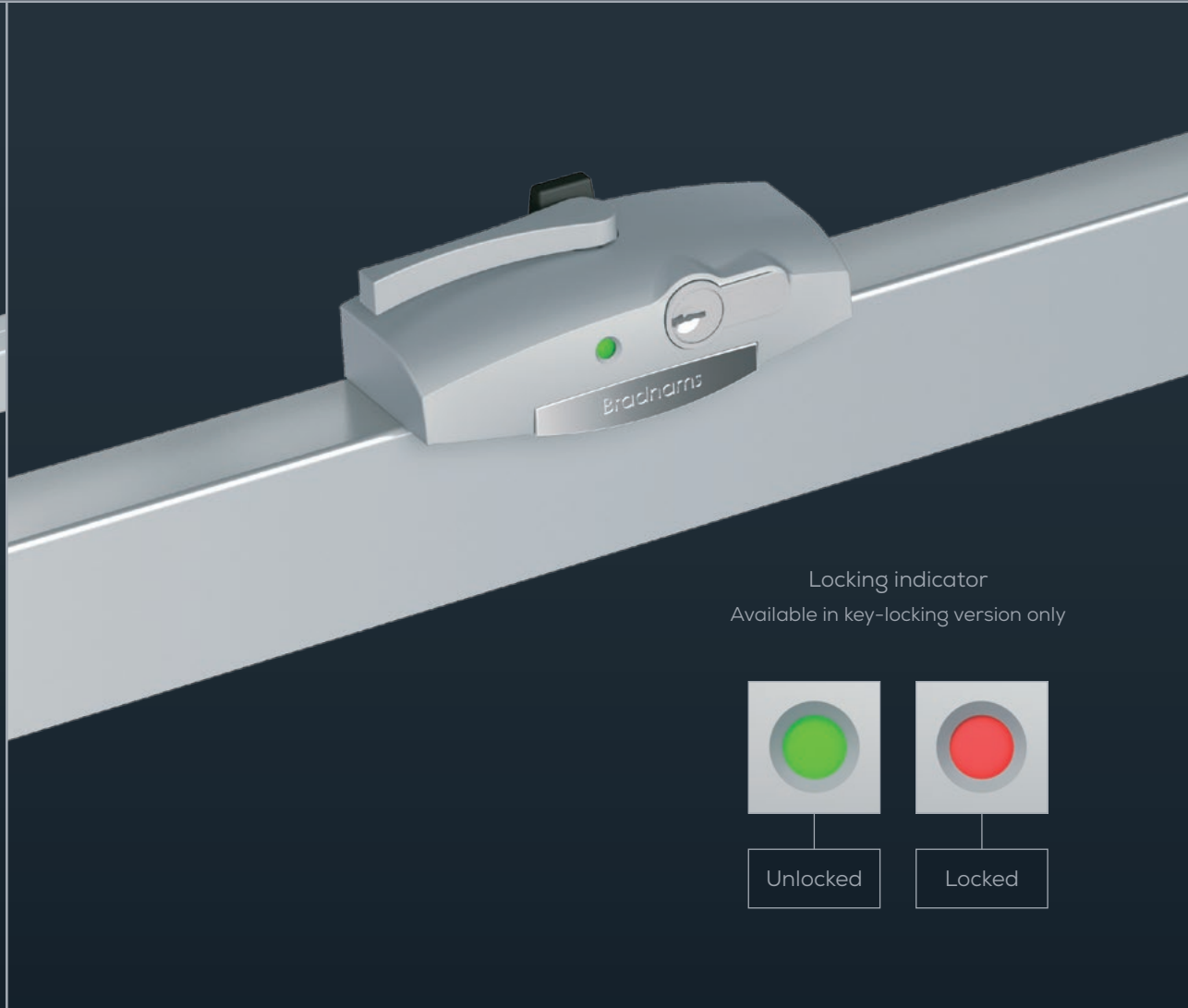
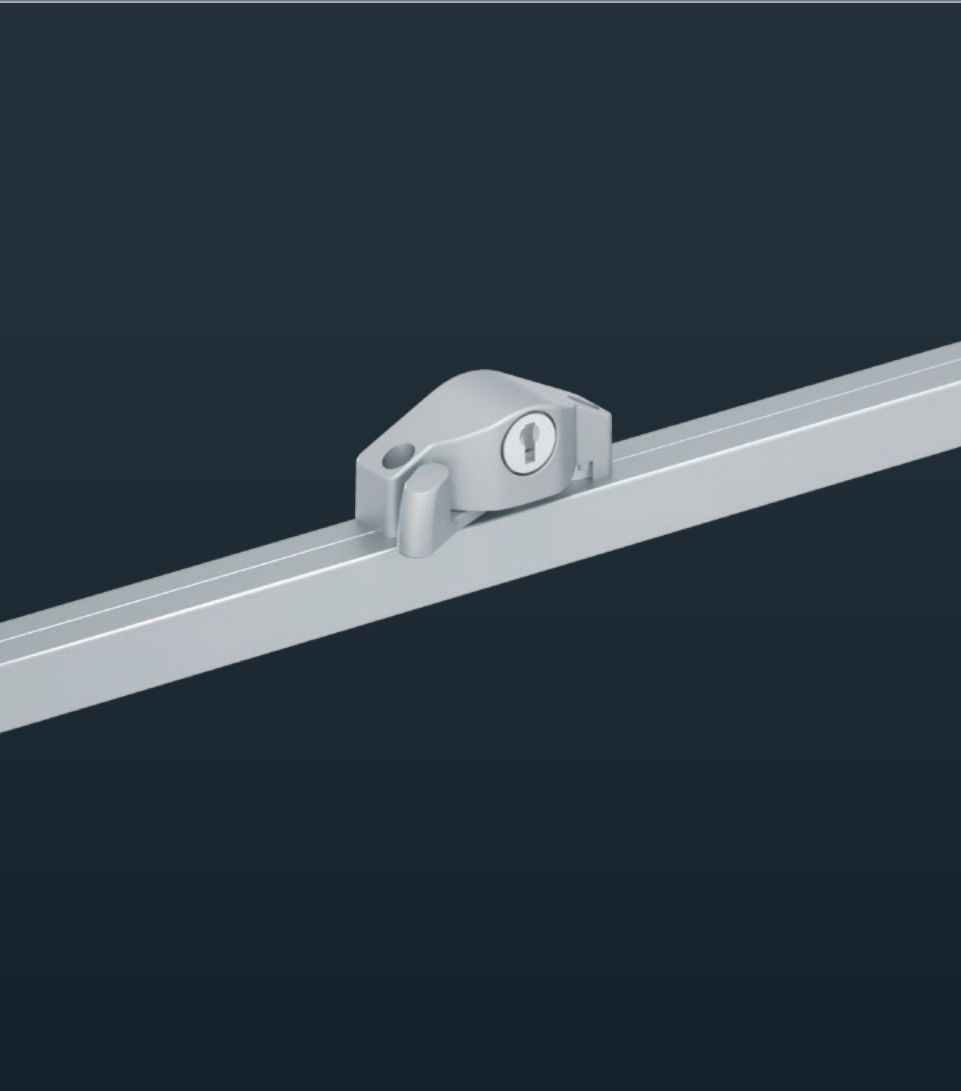

Locking indicator  
Available in key-locking version only



Unlocked



Locked

# AWNING WINDOWS

ESSENTIAL

SIGNATURE

COMMERCIAL

Handles can be folded to minimise interference with window furnishings



Unlocked



Locked

Locking indicator  
Available in key-locking version only

Single chain winder

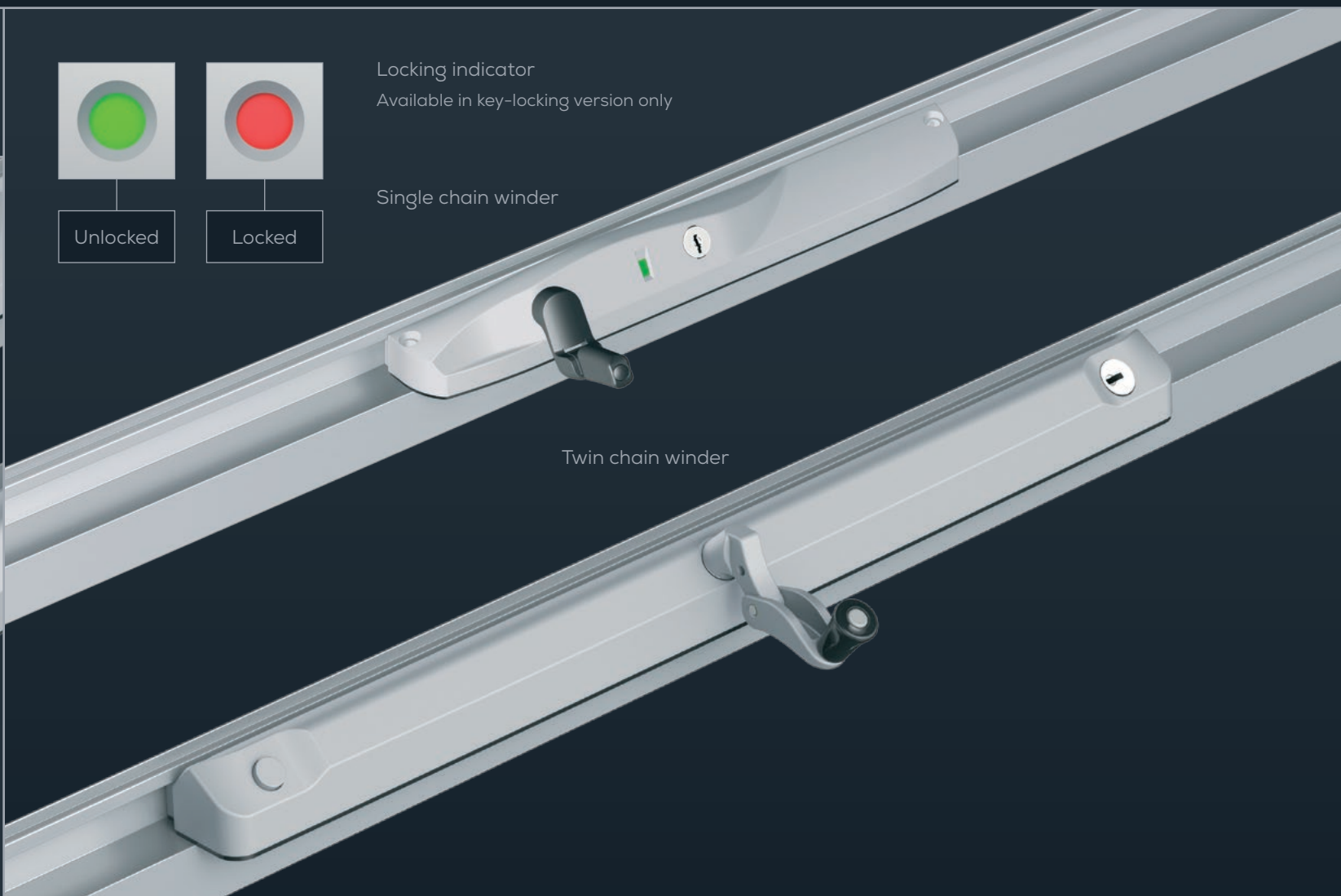

Twin chain winder

# BI-FOLD WINDOWS

SIGNATURE

COMMERCIAL

Signature pull handle

Commercial pull handle

Flush bolt lever

Twin bolt lever



# CASEMENT WINDOWS

## SIGNATURE LB

Lever & key locking system

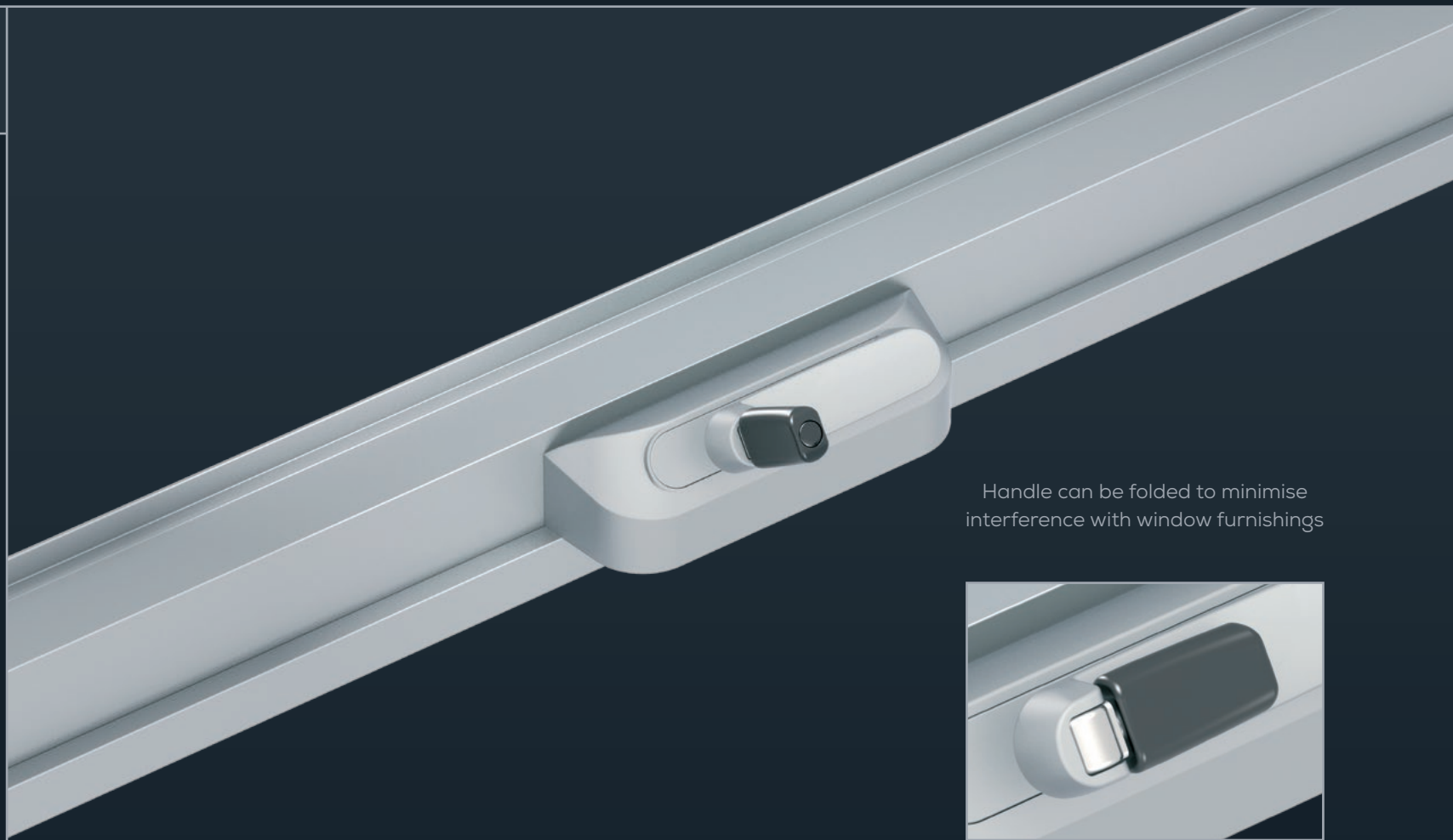

Handle can be folded to minimise interference with window furnishings





# LOUVRE WINDOWS

ESSENTIAL

SIGNATURE

SIGNATURE



	Black Matt	Black Gloss	White	Ultra Silver	Stainless Steel Finish
SLIDING WINDOWS					
Essential	•	•	•	•	
Signature		•	•	•	
DOUBLE HUNG WINDOWS					
Essential		•	•	•	
Signature		•	•	•	
AWNING WINDOWS					
Essential		•	•	•	
Signature		•	•	•	
Commercial		•	•	•	
CASEMENT WINDOWS					
Essential		•	•	•	•
Signature		•	•	•	•
Signature LB		•	•	•	
BI-FOLD WINDOWS					
Signature		•	•	•	
Commercial	•				•

	Black Matt	White	Grey Satin	Surfmist	White Birch	Stone Beige	Woodland Grey
LOUVRE WINDOWS							
Signature	•	•	•	•	•	•	•

Note: Stainless Steel Finish can either be stainless steel substrate or representative plated finish.

The hardware displayed in this catalogue are a guide only, and due to the nature of printing processes, some degree of colour and gloss level variations may occur. We recommend the viewing of an actual hardware product before order.



BRADNAM'S

# DOOR HARDWARE RANGE

SLIDING DOORS

BI-FOLD DOORS

PIVOT DOORS

HINGED DOORS

Comdain Homes

# SLIDING DOORS

ESSENTIAL

SIGNATURE

COMMERCIAL

Standard internal handle

Standard external handle

Lever locks  
the door  
without a key

Mortice lock for improved security



SIGNATURE

COMMERCIAL

Low profile external handle

Internal view

Square-form  
handle

External view

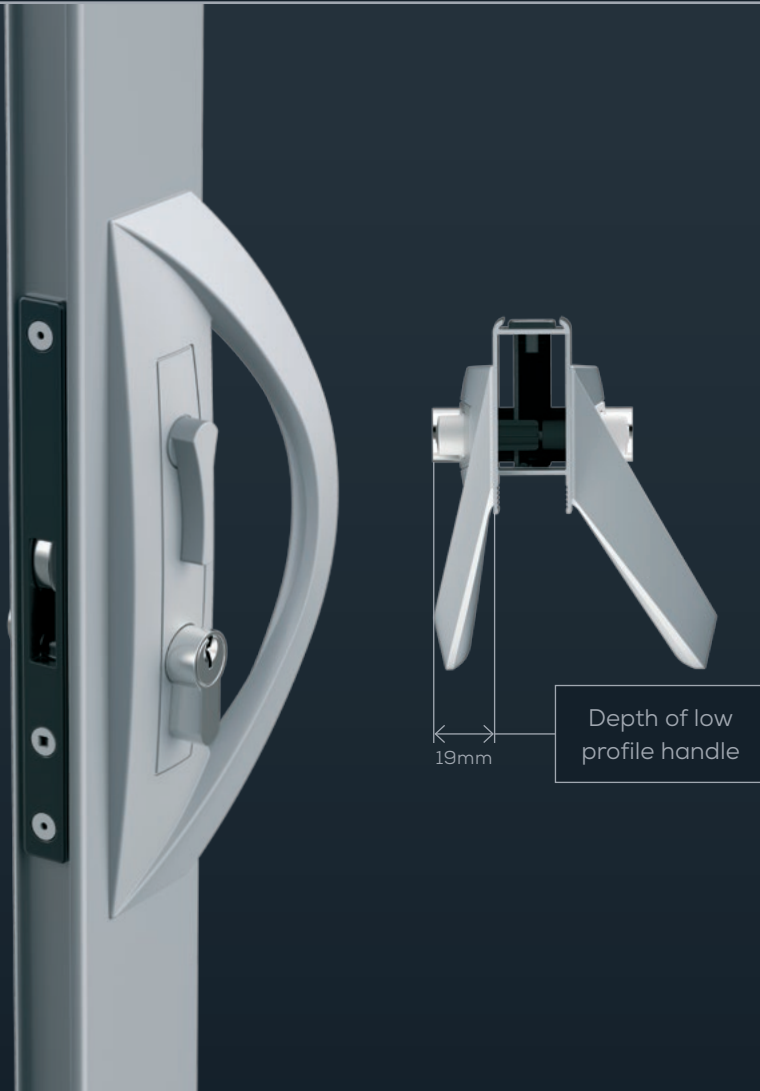

Turn knob cylinder  
available



Lever cylinder



# BI-FOLD DOORS

SIGNATURE

COMMERCIAL

Lever lock

Signature pull handle

Commercial pull handle



# PIVOT & HINGED DOORS

## COMMERCIAL

External key pad



Internal turn knob



# PIVOT & HINGED DOORS

## COMMERCIAL

Lever handle



'D' handles





# PIVOT & HINGED DOORS

## COMMERCIAL

Square-form handles

Curved handle



# HINGED DOORS

ESSENTIAL

SIGNATURE

COMMERCIAL

Flush bolt

Twin bolt

Flush or Twin bolts  
are required for double  
leaf configurations



# BRADNAM'S

# DOOR COLOUR RANGE

	Black Matt	Black Gloss	White	Ultra Silver	Stainless Steel Finish
<b>SLIDING DOORS</b>					
Essential	•	•	•	•	
Signature		•	•	•	
Commercial		•	•	•	•
<b>HINGED DOORS</b>					
Essential		•	•	•	•
Signature		•	•	•	•
Commercial		•	•	•	•
<b>PIVOT &amp; HINGED DOORS</b>					
Commercial					•
<b>BI-FOLD DOORS</b>					
Signature		•	•	•	
Commercial	•				•

Note: Stainless Steel Finish can either be stainless steel substrate or representative plated finish. The hardware displayed in this catalogue are a guide only, and due to the nature of printing processes, some degree of colour and gloss level variations may occur. We recommend the viewing of an actual hardware product before order.

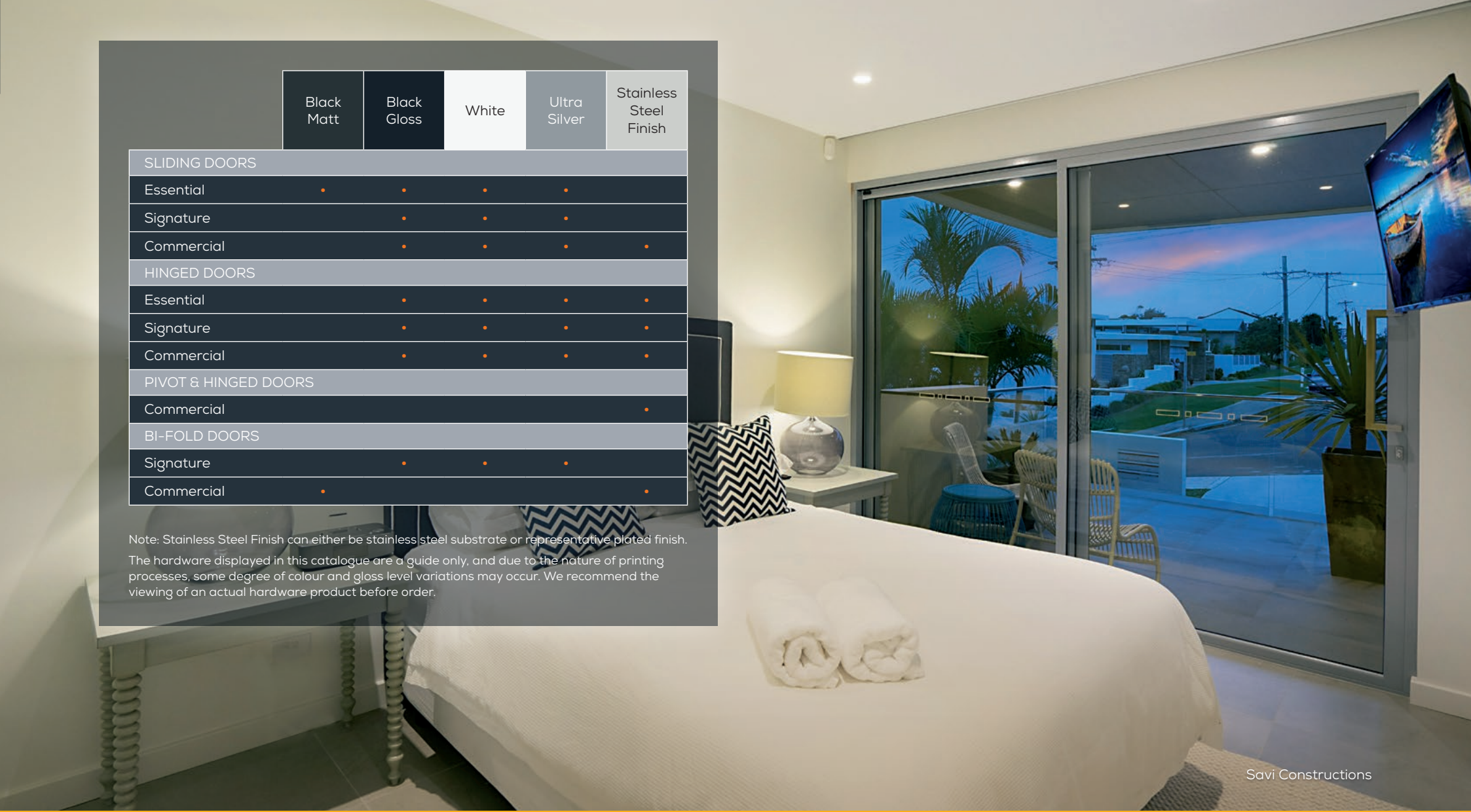

# HARDWARE CARE & MAINTENANCE

General periodic maintenance and care are required on all hardware to ensure that they function correctly and maintain their appearance. The external finish of hardware must be kept clean by removing any harmful residue (especially salt spray) from the surface.

Cleaning should be undertaken with a small amount of mild detergent in warm water. A soft brush or cloth free of grit or buttons should be used. Any form of abrasive cleaner or household cleaners should not be used under any circumstances.

After cleaning it is essential that the hardware is wiped down with fresh water to remove any detergent residue.

Internal mechanisms of locks, catches, etc. should be kept in good working order by applying a light spray of lubricant (WD40, RP7 or similar). Care should be taken during maintenance of internal mechanisms that any finished surface is well protected to avoid damage.

## Recommended Care & Maintenance Intervals

Type of environment	Definition of environment	Maximum maintenance intervals
Mild	Being rural, away from the coast and remote industry and urban activity	6 months
Moderate	Being mainly urban, inland and away from heavy industrial activity	3 months
Tropical / Severe	Being coastal/marine, subject to salt deposition and within 15km of the eastern coast or 10km of the western coast of Australia	2-4 weeks



For more information call Bradnam's on **1300 WINDOWS 1300 946369** or visit [bradnams.com.au](http://bradnams.com.au)

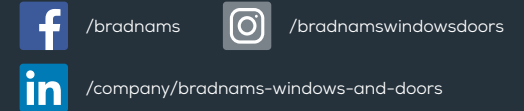

WINDOWS & DOORS

INSECT & SECURITY SCREENS

SHOWER SCREENS

MIRRORS & WARDROBES

GLASS SPLASHBACKS & SHELVING



### Australian Owned & Made

Bradnam's products are proudly made in Australia and designed specifically to meet all Australian conditions.

Hardware availability, features, options, sizes, configurations and performance are subject to regional variations, design requirements and building codes.

Images are for illustration purposes only and may not accurately represent the product. Bradnam's Windows & Doors reserves the right to change, alter or delete any aspect of the hardware range without notice. We recommend visiting a Bradnam's showroom before ordering to view actual hardware.

